

# A Compact Cavity-Backed Monopole Antenna For UWB Applications

Eric Merkley\*<sup>†</sup>, Brad Jackson\*<sup>‡</sup>, Carlos Saavedra<sup>†</sup>, Yahia Antar\*

Electrical and Computer Engineering

\*Royal Military College of Canada,<sup>†</sup>Queen's University  
Kingston, Ontario, Canada

Cyber Operations and Signals Warfare

<sup>‡</sup>Defence Research and Development Canada  
Ottawa, Ontario, Canada

**Abstract**—A new directive ultra wideband (UWB) antenna using a cavity-backed monopole is presented. This compact, broadband, and high-gain antenna consists of a triangular-shaped monopole radiating element along with a tapered cavity. The proposed design uses two pairs of shorting lines to improve radiation pattern consistency at higher frequencies and a tapered cavity to enhance the gain and impedance bandwidth of the antenna. Electromagnetic simulations show an impedance bandwidth with voltage standing wave ratio (VSWR) < 2 from 3.0 GHz to 14.5 GHz (133%) and a gain greater than 6 dBi from 3.0 GHz to 10.8 GHz (113%) with a peak of 10.8 dBi. The proposed antenna is relatively compact with overall dimensions of  $0.65\lambda_l \times 0.32\lambda_l \times 0.18\lambda_l$ , where  $\lambda_l$  is the free-space wavelength of the lowest operating frequency.

## I. INTRODUCTION

Over recent years, ultra wideband (UWB) antennas have become increasingly popular due to the extensive range of potential applications such as radar, medical imaging, and high-data rate wireless communications. As these applications aim to become more portable, it is desirable to minimize the size of the antenna while maintaining high gain and radiation pattern consistency over the antenna bandwidth.

In [1], a symmetrical folded antenna was used in a waveguide structure to attain a directional radiation pattern for use in brain stroke detection. Though achieving a small form factor with a maximum dimension of  $0.29\lambda$ , the impedance bandwidth is relatively small at 63% and it has a low average gain of 3.5 dBi. Alternatively, a cavity-backed printed dipole antenna can be used to achieve a much wider impedance bandwidth with a higher gain [2]. However, this comes at the cost of increasing the antenna dimensions.

Various other antenna designs have been proposed for directive UWB applications such as a U-shaped bow-tie dipole [3], or cavity-backed bow-tie antenna [4]. The goal in these investigations was to increase impedance bandwidth, peak gain, and gain bandwidth while decreasing antenna size as much as possible. However, in realizing each of these designs one attribute typically suffers a degradation as another improves.

The antenna design in [5] uses a cavity-backed rectangular aperture modified-dipole antenna to achieve an impedance bandwidth (VSWR < 2.5) from 1.08 GHz to 4.9 GHz (128%) with a peak gain of 11 dBi. However, in that work the input impedance of the bow-tie antenna was  $100 \Omega$ . Therefore the design required an impedance transforming balun in order to be matched to a  $50 \Omega$  system, which complicates both the

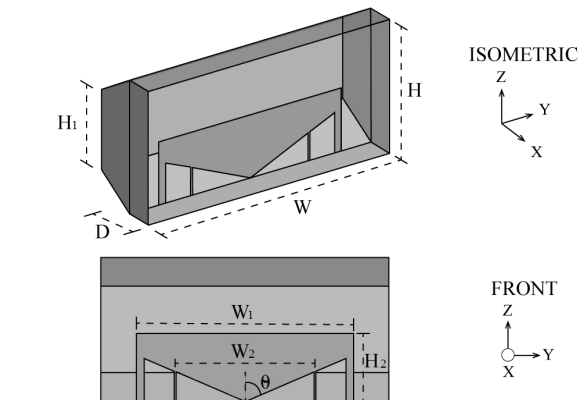

Fig. 1: Structure of the proposed antenna.

design and fabrication of the antenna. To address this issue, a new compact UWB directive antenna is presented in this work using a cavity-backed monopole that eliminates the need for an impedance transforming balun. Techniques for enhancing the bandwidth, radiation patterns, and gain are also presented for the proposed design.

## II. ANTENNA DESIGN

The input impedance and operating frequency of a bow-tie antenna structure are directly related to the bow-tie angle and length, respectively [6]. Full-wave EM simulations showed that cavity-backed bow-tie dipole implementations achieve more desirable radiation patterns (i.e., a single high gain main lobe at boresight) within the impedance bandwidth when matched to  $100 \Omega$ . To eliminate the need for a balun and impedance transformation as in [5], a half bow-tie monopole design was implemented in this work as shown in Fig. 1. The radiating element could be fed by a coaxial probe through a hole in the bottom of the cavity. This design enables a  $TE_{10}$  field distribution at the aperture of the antenna despite

TABLE I: Dimensions of proposed antenna.

Variable	Value (mm)	Variable	Value (mm)
H	32.3	W	64.6
H <sub>1</sub>	24.8	W <sub>1</sub>	48.1
H <sub>2</sub>	30.5	W <sub>2</sub>	15.7
D	17.9	$\theta$	67°

the shorted waveguide's electrically small size. The proposed antenna's dimensions are presented in Table I.

There are two symmetrical sets of conducting lines on the monopole which are used to combat the resonance created between the side-walls and the monopole feed at frequencies within the operating band. The outer and inner pairs have widths of 0.4 mm and 1.7 mm, respectively, which could be implemented with thin wires. These lines enhance the boresight directivity at high frequencies. The taper at the back end of the cavity provided significant matching improvements at the low end of the operational band as will be shown in the following section. At the lowest operational frequency,  $f_l=3.0$  GHz, the wavelength is  $\lambda_l = 100$  mm. The overall width, height, and depth dimensions of the antenna relative to  $f_l$  are therefore  $0.65\lambda_l \times 0.32\lambda_l \times 0.18\lambda_l$ .

### III. SIMULATION RESULTS

The proposed antenna was designed and simulated with FEKO [7], using the method of moments. The results are presented in comparison to an identical cavity-backed monopole antenna without the conducting lines and tapered cavity, referred to as the 'original' design. The H- and E-plane radiation patterns at 5.0 GHz and 9.0 GHz are shown in Fig. 2. These patterns show the improvements with respect to gain across the operational band. The proposed and original antennas provide similar patterns at low frequencies. The proposed antenna maintained peak H-plane gain at boresight from 3.0 GHz to 11.0 GHz while the original antenna's H-plane pattern is distorted from 4.8 GHz to 6.1 GHz and beyond 10.1 GHz.

The reflection coefficient and gain at boresight versus frequency can be seen in Fig. 3. Tapering the back of the antenna cavity provided important matching improvements from 3.0 GHz to 5.6 GHz giving the proposed antenna an impedance bandwidth of 3.0 GHz to 14.5 GHz (133%) with a VSWR  $< 2$  ( $|S_{11}| < -10$  dB).

The gain of the proposed antenna is shown to be higher than that of the equivalent monopole over the entire operational bandwidth. The gain is at least 6 dBi from 3.0 GHz to 10.8 GHz resulting in a gain bandwidth of 113%. The gain bandwidth of the original design (gain  $> 6$  dBi) occurs between 6.3–10.0 GHz (46%). Additionally, the proposed antenna maintains near-peak gain ( $> 9$  dBi) from 6.4–10.3 GHz with a peak of 10.8 dBi occurring at approximately 8.7 GHz.

### IV. CONCLUSION

A compact ultra wideband cavity-backed monopole antenna with bandwidth and gain enhancement has been designed and simulated. Conducting lines and a tapered cavity were added to the monopole element to enhance radiation pattern directivity and improve input impedance matching. Relative to previous designs of this type, the proposed antenna exhibits wider impedance and gain bandwidths while achieving a similar form factor. Furthermore, the proposed design eliminates the need for an impedance transformer and balun, simplifying the design and fabrication, and potentially reducing cost.

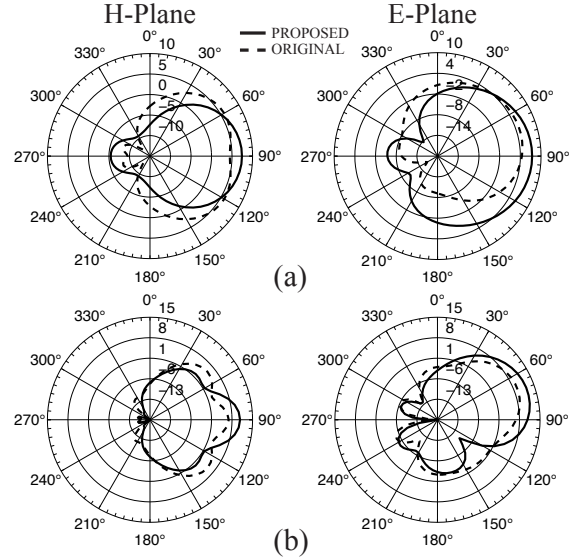

Fig. 2: H- and E-plane patterns (gain in dBi) at (a) 5.0 GHz and (b) 9.0 GHz.

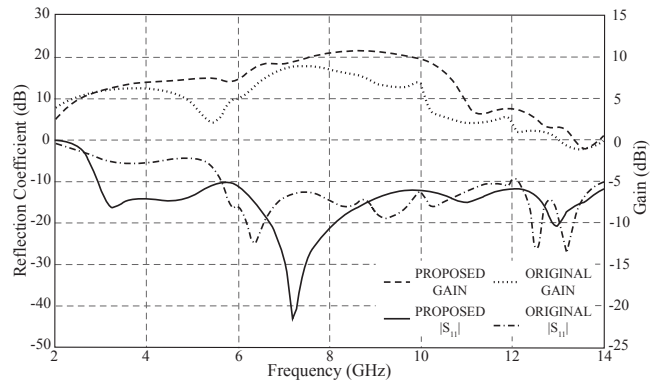

Fig. 3: Reflection coefficient and boresight gain of the proposed and original antennas.

### REFERENCES

- [1] A.T. Mobashsher, and A. Abbosh, "Development of Compact Directional Antenna Utilising Place of Symmetry for Wideband Brain Stroke Detection Systems", *Electronics Letters* 50, no. 12, pp. 850-851, 5 June 2015.
- [2] J.Y. Li, R. Xu, X. Zhang, S-G. Zhou, and G-W. Yang, "A Wideband High-Gain Cavity-Backed Low-Profile Dipole Antenna", *IEEE Transactions on Antennas and Propagation*, Vol. 64, pp.5465-5469, December 2016.
- [3] B. Feng, S. Li, W. An, S. Yin, J. Li, and T. Qiu, "U-shaped Bow-Tie Magneto-Electric Dipole Antenna With a Modified Horned Reflector for Ultra-Wideband Applications", *IET Microwaves, Antennas, and Propagation*, Vol. 8, pp.990-998, March 2014.
- [4] S-W. Qu, J-L. Li, Q. Xue, and C.H. Chan, "Wideband Cavity-Backed Bowtie Antenna With Pattern Improvement", *Global Symposium on Millimeter Waves*, Vol. 56, pp.3850-3854, December 2008.
- [5] A. Elsherbini, and K. Sarabandi, "Compact Directive Ultra-Wideband Rectangular Waveguide Based Antenna for Radar and Communications Applications", *IEEE Transactions on Antennas and Propagation*, Vol. 60, pp.2203-2209, May 2012.
- [6] D.A. Abd El-Aziz, T.G. Abouelnaga, E.A. Abdallah, M. El-said, and Y.S.E. Abdo, "Analysis and Design of UHF Bow-Tie RFID Tag Antenna Input Impedance", *Open Journal of Antennas and Propagation*, Vol. 4, pp.85-107, June 2016.
- [7] FEKO ver. 14.0, Stellenbosch, South Africa, Altair Engineering, Inc.